



LA DRAGAGGI s.r.l.

Via Luigi Kossut nr. 6 - 30175 MARGHERA (VE)

tel. 041 937014 - fax 041 937024

e-mail: segreteria@ladragaggi.it - www.ladragaggi.eu

STAZIONE BOOSTER



DRAGAGGI - RIPASCIMENTI SPIAGGE

RIQUALIFICAZIONI AMBIENTALI

RIPRISTINO MORFOLOGIE LAGUNARI

RECUPERI MARITTIMI

COSTRUZIONI MARITTIME

ELEMENTI DI INDIVIDUAZIONE

<i>Nome</i>	STAZIONE BOOSTER
<i>Tipologia</i>	<i>Pompa Dragante e Stazione Refluente</i>
<i>DN</i>	400
<i>Lunghezza</i>	10m x 3m

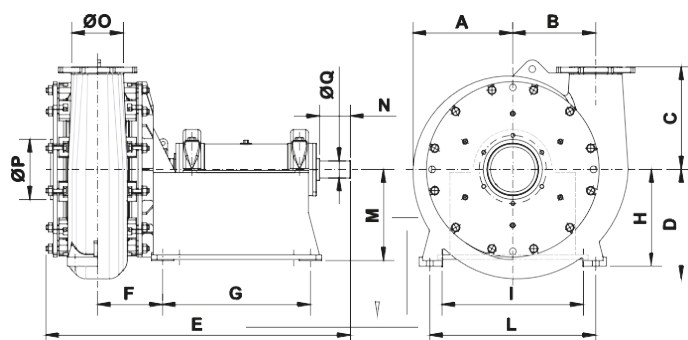

Pompa PD	400
Ø Mandata	401
Ø Aspirazione	440
Passaggio solido max.	260
Ø Girante	1120
Peso	9
Prevalenza manometro totale	80
Portata minima miscela	1350
Portata massima miscela	2400
Portata indicativa in solido	400

PD	A	B	C	D	E	F	G	H	I	L	M	N	O	P	Q
400	905	760	875	1000	2615	540	675x2	800	1250	1650	750	230	400	450	140